

NOTE:
Please read all instructions
carefully before using this
product

Table of Contents

Safety Notice

Hardware Identifier

Assembly Instruction

Parts List

Warranty

Ordering Parts

Model
MKB-957

Retain This
Manual for
Reference

210111

OWNER'S
MANUAL

MARCY®

MARCY® CLUB OLYMPIC BENCH MKB-957

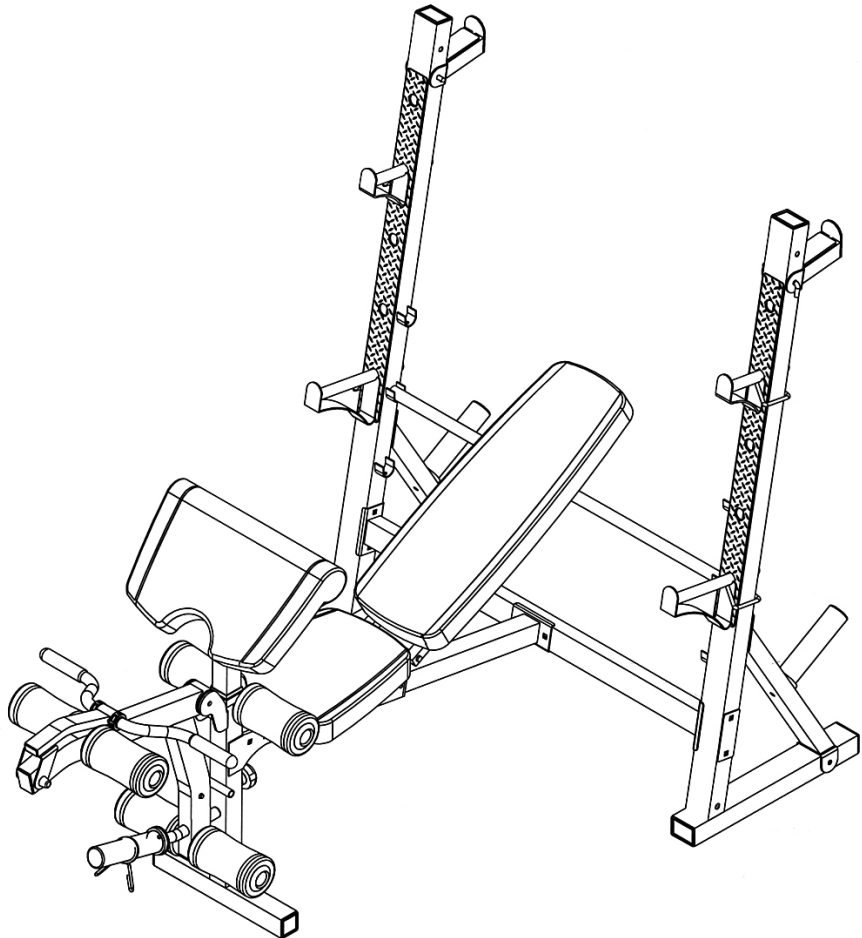

IMPORTANT: Please read this manual before commencing
assembly of this product.

IMPEX® INC.

2801 S. Towne Ave, Pomona, CA 91766

Tel: 800-999-8899

www.marcypro.com

support@impex-fitness.com

TABLE OF CONTENTS

BEFORE YOU BEGIN	1
IMPORTANT SAFETY NOTICES	2
EXERCISE GUIDELINES	3
WARNING LABEL PLACEMENT	5
FREE AND TRAINING AREA	6
IMPORTANT ASSEMBLY INFORMATION	7
CARE AND MAINTENANCE	7
WEIGHT CAPACITY AND DIMENSIONS	8
PARTS LIST	8
EXPLODED DIAGRAM	9
WARRANTY	10
ORDERING PARTS	10

BEFORE YOU BEGIN

Thank you for selecting the Marcy CLUB MKB-957 OLYMPIC BENCH by IMPEX® INC. For your safety and benefit, read this manual carefully before using the machine. As a manufacturer, we are committed to provide you complete customer satisfaction. If you have any questions, or find there are missing or damaged parts, we guarantee you complete satisfaction through direct assistance from our factory. To avoid unnecessary delays, *please call our TOLL-FREE customer service number*. Our Customer Service Agents will provide immediate assistance to you.

Toll-Free Customer Service Number

1-800-999-8899

Mon. – Fri. 9 a.m. – 5 p.m. PST

www.marcypro.com

support@impex-fitness.com

IMPORTANT SAFETY NOTICE

PRECAUTIONS

This exercise machine is built for optimum safety. However, certain precautions apply whenever you operate a piece of exercise equipment. Be sure to read the entire manual before you assemble or operate your machine. In particular, note the following safety precautions:

1. **Keep children and pets away from the machine at all times. DO NOT leave children unattended in the same room with the machine.**
2. Only one person at a time should use the machine.
3. If the user experiences dizziness, nausea, chest pain, or any other abnormal symptoms, STOP the workout at once. CONSULT A PHYSICIAN IMMEDIATELY.
4. Position the machine on a clear, leveled surface. DO NOT use the machine near water or outdoors.
5. Keep hands away from all moving parts.
6. Always wear appropriate workout clothing when exercising. DO NOT wear robes or other clothing that could become caught in the machine. Running or aerobic shoes are also required when using the machine.
7. Use the machine only for its intended use as described in this manual. DO NOT use attachments not recommended by the manufacturer.
8. Do not place any sharp object around the machine.
9. Disabled person should not use the machine without a qualified person or physician in attendance.
10. Before using the machine to exercise, always do stretching exercises to properly warm up.
11. Never operate the machine if the machine is not functioning properly.
12. A spotter is recommended during exercise.

CARE AND MAINTENANCE

1. Inspect and tighten all parts before using the machine.
2. The machine can be cleaned using a damp cloth and mild non-abrasive detergent. DO NOT use solvents.
3. Maximum on Bar Catch: 300 lbs
4. Maximum weight on Leg Developer: 100 lbs
5. Maximum user weights: 300 lbs
4. Maximum weight capacity 600 lbs (include user's weight).

WARNING: BEFORE BEGINNING ANY EXERCISE PROGRAM, CONSULT YOUR PHYSICIAN. THIS IS ESPECIALLY IMPORTANT FOR INDIVIDUALS OVER THE AGE OF 35 OR PERSONS WITH PRE-EXISTING HEALTH PROBLEMS. READ ALL INSTRUCTIONS BEFORE USING ANY FITNESS EQUIPMENT. IMPEX INC. ASSUMES NO RESPONSIBILITY FOR PERSONAL INJURY OR PROPERTY DAMAGE SUSTAINED BY OR THROUGH THE USE OF THIS PRODUCT.

SAVE THESE INSTRUCTIONS.

Building Muscle and Gaining Weight

Unlike aerobic exercise, which emphasizes endurance training, anaerobic exercise focuses on strength training. A gradual weight gain can occur while building the size and strength of muscles. While developing muscle mass, your body adapts to the stress placed upon it. You can modify your diet to include foods such as meat, fish and vegetables. These foods help muscles recover and replenish important nutrients after a strenuous workout.

Muscle Strength and Endurance

To achieve the greatest benefit from exercise, it is important to develop an exercise program that allows you to work all of the major muscle groups equally.

To increase muscles strength; follow this principle:

Increasing resistance and maintaining the number of repetitions of an exercise results in increased muscle strength.

To tone your body, follow the principle: Decreasing resistance plus increasing the number of repetitions of an exercise results in increased body tone.

Once you feel comfortable with an exercise, you can change the resistance, the number of repetitions, or the speed at which you do the exercise. It is not necessary to change all three variables. For example, let's say that you are training at 50 lbs and performing the exercise 10 times in 3 minutes. When this becomes too easy, you may decide to move up lifting 60 lbs for the same number of repetitions in the same amount of time. Lifting more weights fewer times most often develops muscle strength. To gain both muscle strength and endurance, it is recommended that you perform each exercise 15 to 20 reps per set.

Training Intensity

How hard you begin to train depends on your overall level of fitness. The soreness you experienced can be lessened by decreasing the load you place on your muscles and by performing fewer sets. To avoid injury, you should gradually work into an exercise program and set the load to your individual fitness level. The load should increase as your fitness level increases.

Muscle soreness is common, especially when you first start exercising. If you are painfully sore for a long time, it may be time to change your program. Eventually, your muscle system will become accustomed to the stress and strain placed on it.

Beginning a Strength Building Program

Warming Up

To begin strength training, it is important to stretch and perform light exercise for 5 to 10 minutes. This helps prepare the body for more strenuous exercise by increasing circulation, raising your body temperature and developing more oxygen to your muscles.

Workout

Each workout to keep in mind that muscle soreness that lasts for a long period is not desirable and may mean that injury has occurred.

Cool Down

At the end of each workout, perform slow stretching exercises for 5 to 10 minutes. Ease into each stretch only going as far as you can. This stage allows your muscles wind down after training.

To provide a total workout program it is also recommended that 2 to 3 days of aerobic exercise is performed in addition to the strength training.

Drinking Water

For the body to function properly, it must be properly hydrated. If you are exercising, you should increase your fluid intake. The reason for this is that the water you take in will leave your system through the sweating mechanism that cools your body during exercise. The water you lose through exercise must be replaced so that the muscles can recover properly.

Rest Day

Although you may not feel like doing it, taking a rest day at least once a week is important because it gives your body a chance to heal itself. Continuously working your muscle will result in over training which will not benefit in the long run.

WARNING LABEL PLACEMENT

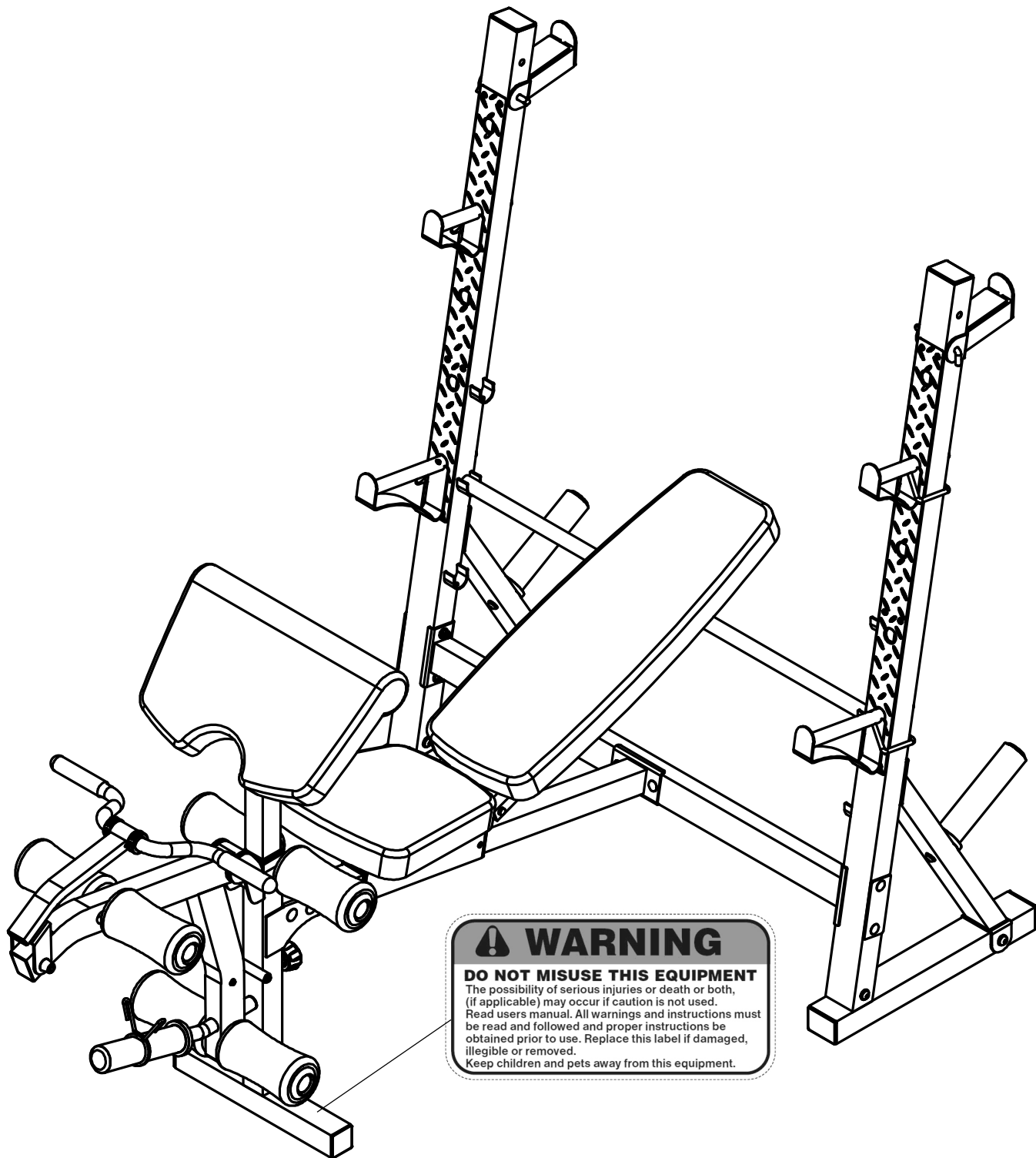

The Warning Label shown here has been placed on the Front Stabilizer. If the label is missing or illegible, please call customer service at 1-800-999-8899 for replacement. Apply the label in location shown.

FREE AND TRAINING AREA

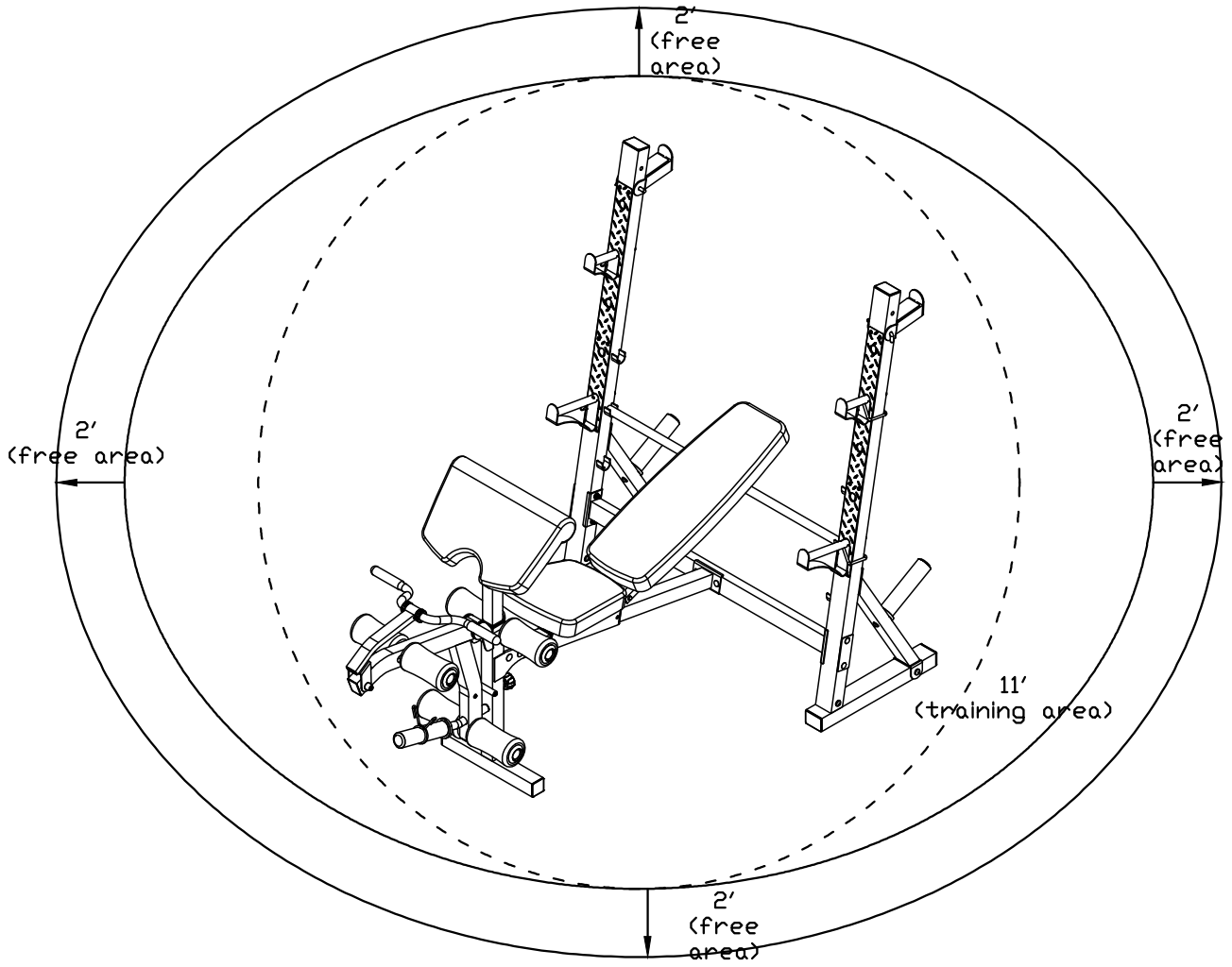

IMPORTANT ASSEMBLY INFORMATION

- ❖ Tools Required for Assembling the Bench: Two Adjustable Wrenches and Allen Wrenches.
- ❖ NOTE: It is strongly recommended that this equipment is assembled by two or more people to avoid possible injury.
- ❖ Ensure **Carriage Bolts** are inserted through the **SQUARE holes** on components that need to be assembled. Attach washer only to end of the Carriage Bolt.
- ❖ Use **Allen Bolts or Hex Bolts** inserted through the **ROUND hole** on components that need to be assembled.
- ❖ Always wait until all bolts are assembled onto the bench before tightening the bolts. Do not tighten each bolt right after it is installed

Fasten Nuts and Bolts

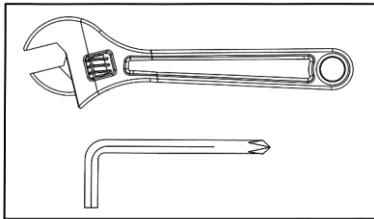

Securely tighten all Nuts and Bolts after all components have been assembled in current and previous steps.

NOTE: Do not over tighten any component with pivoting function.

Make sure all pivoting components are able to move freely.

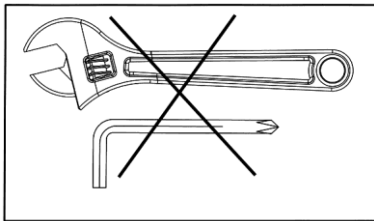

Do not tighten all Nuts and Bolts in this step.

CARE AND MAINTENANCE

1. Lubricate moving parts with WD-40 or light oil periodically.
2. Inspect and tighten all parts before using the equipment.
3. The equipment can be cleaned using a damp cloth and mild non-abrasive detergent. **DO NOT** use solvents.
4. Examine the equipment regularly for signs of damages or wear.
5. Replace any defective components immediately and/or keep the equipment out of use until repair.
6. **Failure to examine regularly may affect the safety level of the equipment.**

WEIGHT CAPACITY AND DIMENSION

1. Maximum User weight: 300 lbs.
2. Assembled Dimension: 79.53" x 48" x 60.63"

PARTS LIST

Part #	DESCRIPTION	Q'ty
1	Left Upright Beam	1
2	Right Upright Beam	1
3	Rear Stabilizer	2
4	Main Seat Support	1
5	Cross Brace	1
6	Backrest Adjustment Bar	1
7	Squat Bar Catch	2
8	Rear Diagonal Support	2
9	Arm Curl Stand	1
10	Leg Developer	1
11	Curl Bar Handle Support	1
12	Curl Bar Handle	1
13	Leg Developer Support	1
14	Front Stabilizer	1
15	Sliding Block	1
16	Left Bar Catch	1
17	Right Bar Catch	1
18	Left Safety Catch	1
19	Right Safety Catch	1
20	Seat Bracket	1
21	Backrest Support	2
22	Foam Tube	3
23	4 3/4" x 2" Bracket	3
24	Weight Post	2
25	Panel	2
26	Backrest Board	1
27	Seat Pad	1
28	Arm Curl Pad	1
29	Rivet	20
30	Olympic Sleeve	3
31	Foam Roll	6
32	Foam Roll End Cap	6
33	1 5/8" x 2 3/8" End Cap	2
34	2" Square End Cap	2
35	2 3/4" x 2" End Cap	6
36	1" Square End Cap	2

Part #	DESCRIPTION	Q'ty
37	1 5/8" x 3/4" End Cap	1
38	Ø 1" End Cap	8
39	Ø 2 3/8" Bushing	2
40	2 3/8" x 2" Sleeve	2
41	2" x 1 3/4" Sleeve	1
42	M18 Lock Knob	2
43	Rubber Bumper	2
44	Ø 1 1/2" Plastic Ring	4
45	Ø 1/2" Bushing	2
46	Curl Bar Handle Grip	2
47	M6 x 1/2" Philips Screw	1
48	Ø 1/2" Washer	1
49	U-shaped Pin	1
50	Spring	1
51	4 1/2" L-shaped Pin	2
52	3 7/8" Lock Pin	1
53	4" L-shaped Pin	1
54	Spring Clip	1
55	Axle	1
56	M10 x 3 1/2" Carriage Bolt	4
57	M10 x 2 3/4" Carriage Bolt	2
58	M10 x 2 1/2" Carriage Bolt	1
59	M10 x 2 3/8" Carriage Bolt	2
60	M10 x 3 3/4" Allen Bolt	2
61	M10 x 4 3/4" Allen Bolt	1
62	M10 x 3/4" Allen Bolt	2
63	M10 x 5/8" Allen Bolt	13
64	M8 x 5/8" Allen Bolt	6
65	M8 x 1 5/8" Allen Bolt	4
66	Ø 3/4" Washer	30
67	Ø 5/8" Washer	10
68	M10 Aircraft Nut	12
	4# Allen Wrench	1
	5# Allen Wrench	1
	6# Allen Wrench	2

EXPLODED DIAGRAM

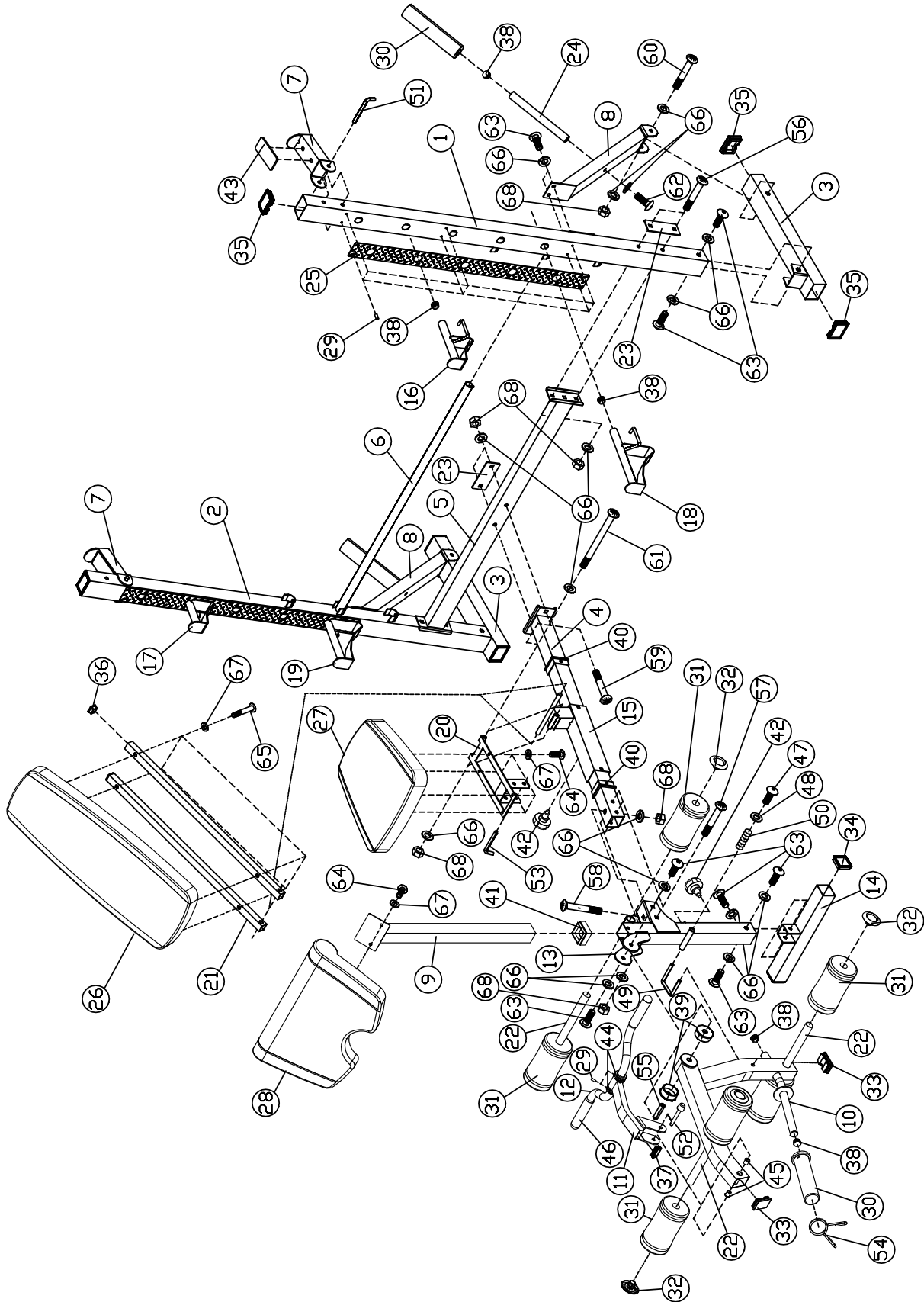

IMPEX[®] INC.

LIMITED WARRANTY

IMPEX Inc. ("IMPEX[®]") warrants this product to be free from defects in workmanship and material, under normal use and service conditions, for a period of two years on the Frame from the date of purchase. This warranty extends only to the original purchaser. IMPEX's obligation under this Warranty is limited to replacing or repairing, at IMPEX's option.

All returns must be pre-authorized by IMPEX. Pre-authorization may be obtained by calling IMPEX Customer Service Department at 1-800-999-8899. All freights on products returned to IMPEX must be prepaid by the customer. This warranty does not extend to any product or damage to a product caused by or attributable to freight damage, abuse, misuse, improper or abnormal usage. No other warranty beyond that specifically set forth above is authorized by IMPEX.

IMPEX is not responsible or liable for indirect, special or consequential damages arising out of or in connection with the use or performance of the product or other damages with respect to any economic loss, loss of property, loss of revenues or profits, loss of enjoyments or use, costs of removal, installation or other consequential damages or whatsoever natures. Some states do not allow the exclusion or limitation of incidental or consequential damages. Accordingly, the above limitation may not apply to you.

The warranty extended hereunder is in lieu of any and all other warranties and any implied warranties of merchantability or fitness for a particular purpose is limited in its scope and duration to the terms set forth herein. Some states do not allow limitations on how long an implied warranty lasts. Accordingly, the above limitation may not apply to you.

This warranty gives you specific legal right. You may also have other rights which vary from state to state. **Register on-line at www.marcypro.com**

IMPEX[®] INC.
2801 S. Towne Ave.
Pomona, CA 91766

ORDERING REPLACEMENT PARTS

Replacement parts can be ordered by calling our Customer Service Department toll-free at **1-800-999-8899** during our regular business hours: Monday through Friday, 9 am until 5 pm Pacific standard time.

Support@impex-fitness.com

When ordering replacement parts, always give the following information.

1. Model
2. Description of Parts
3. Part Number
4. Date of Purchase